

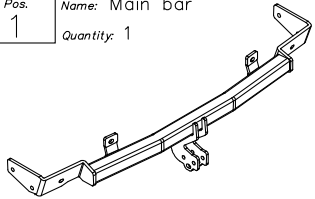

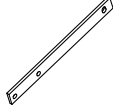







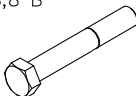

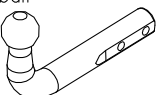
## Towbar accessories:

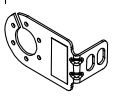
Pos. 1	Name: Main bar Quantity: 1	Pos. 5	Name: Jib Quantity: 2	Pos. 10	Name: Washer Quantity: 6 Dim.: $\phi 35 \times \phi 12 \times 3 \text{mm}$
					
		Pos. 6	Name: Bolt 8,8 B Quantity: 2 Dim.: M12x75mm	Pos. 11	Name: Plain washer Quantity: 2 Dim.: $\phi 13 \text{ mm}$
					
Pos. 2	Name: Tow ball Quantity: 1	Pos. 7	Name: Bolt 8,8 B Quantity: 10 Dim.: M10x35mm	Pos. 12	Name: Plain washer Quantity: 10 Dim.: $\phi 10,5 \text{ mm}$
					
Pos. 3	Name: Socket plate Quantity: 1	Pos. 8	Name: Nut 8 B Quantity: 2 Dim.: M12	Pos. 13	Name: Spring washer Quantity: 2 Dim.: $\phi 12,2 \text{ mm}$
					
Pos. 4	Name: Ball cover Quantity: 1	Pos. 9	Name: Nut 8 B Quantity: 10 Dim.: M10	Pos. 14	Name: Spring washer Quantity: 10 Dim.: $\phi 10,2 \text{ mm}$
					



**PPUH AUTO-HAK Sp.J.**

Produkcja Zaczepów Kulowych  
Henryk & Zbigniew Nejman  
76-200 SŁUPSK ul. Słoneczna 16K  
tel/fax (059) 8-414-414; 8-414-413  
E-mail: [office@autohak.com.pl](mailto:office@autohak.com.pl)  
[www.autohak.com.pl](http://www.autohak.com.pl)

## Towing hitch (without electrical set)

Class: **A50-X** Cat. no. **P22**

Designed for:

Manufacturer: **CITROEN**

Model: **XANTIA**

Type: **5 door**

produced since 1993 till 2000

Technical data:

**D-value: 9,1 kN**

maximum trailer weight: **1600 kg**

maximum vertical cup load: **85 kg**

**Approval number according to Directive 94/20/EC: e20\*94/20\*0049\*00**

## Foreword

This towbar is designed according to rules of safety traffic regulations. The towing hitch is a safety component and can be install only by qualified personnel. Any alteration or conversion of the towing hitch is prohibited and would lead to cancellation of design certification. Remove insulating compound and underseal from vehicle (if present) in the area of the matting surfaces of the towing hitch.

The vehicle manufacturer's specifications regarding trailer load and max. vertical cup load are decisive for driving, and values for the towing hitch cannot be exceeded.

*D-value formula:*

$$\frac{\text{Max trailer weight [kg]} \times \text{Max vehicle weight [kg]}}{\text{Max trailer weight [kg]} + \text{Max vehicle weight [kg]}} \times \frac{9,81}{1000} = D \text{ [kN]}$$

## FITTING INSTRUCTION

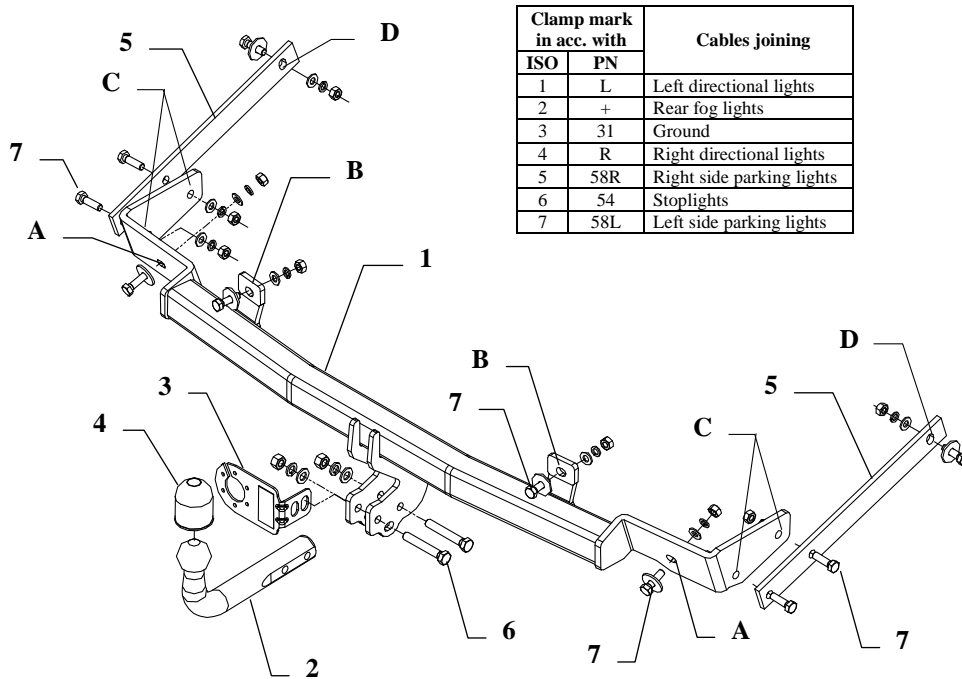

Clamp mark in acc. with		Cables joining
ISO	PN	
1	L	Left directional lights
2	+	Rear fog lights
3	31	Ground
4	R	Right directional lights
5	58R	Right side parking lights
6	54	Stoplights
7	58L	Left side parking lights

Fig.1

This towbar is designed to assembly in following car:  
**CITROEN XANTIA 5 door**, produced since 1993 till 2000, catalogue no. **P22** and is prepared to tow trailers max total weight **1600 kg** and max vertical load **85 kg**.

### *From manufacturer*

Thank you for buying our product. Their reliability has been confirmed in many tests. Reliability of towbar depends also on correct assembly and right operation. For this reasons we kindly ask to read carefully this instruction and apply to hints.

*The towbar should be install in points described by a car producer.*

## The instruction of the assembly

1. Disassemble the bumper.
2. Put main bar of the towbar (pos. 1) to rear part of the car and through existing holes and holes in the towbar (pos. A and B) fix it using bolts M10x35mm (pos. 7), use washers (pos. 10) as showed in the fig.1. Fix loosely.
3. Fix elements (pos. 5) through holes (pos. C) using bolts M10x35mm, next through holes (pos. D) in element (pos. 5) fix to original holes in the car using bolts M10x35mm and washers (pos. 10) (as showed in the drawing).

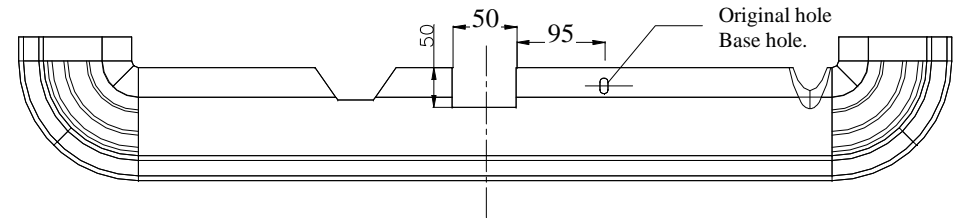

Fig. 2. Bumper cut out

4. Fix all bolts according to the torque shown in the table.
5. Reassemble the bumper after cut out his fragment in lower part (as shown in the fig. 2).
6. Fix tow-ball (pos. 2) and socket plate (pos. 3) using bolts M12x75mm (pos. 6) from accessories.
7. Connect electric wires according to the instruction of the car. (Recommend to make at authorized service station).
8. Supplement the paint coating damaged during assembly.

### Torque settings for nuts and bolts (8,8):

<b>M6</b> - 11 Nm	<b>M 8</b> - 25 Nm	<b>M 10</b> - 50 Nm
<b>M 12</b> - 87 Nm	<b>M 14</b> - 138 Nm	<b>M16</b> - 210 Nm

### NOTE

After install the towbar you should get adequate note in registration book (at authorised service station).The car should be equipped with:

- Indicators
- Tow mirrors

After 1000km of exploitation check all bolts and nuts. The ball of towbar must be always kept clear and conserve with a grease.



[ahkupplungen.de](http://ahkupplungen.de)