

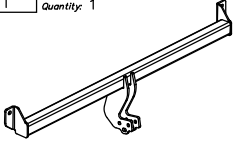











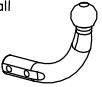



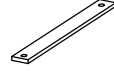

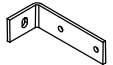



**Towbar accessories:**

|   |  |   |  |
|---|--|---|--|
| Pos. 1<br>Name: Main bar<br>Quantity: 1<br>                         | Pos. 6<br>Name: Plate<br>Quantity: 2<br>  | Pos. 12<br>Name: Bolt 8,8 B<br>Quantity: 2<br>Dim.: M10x75mm<br> | Pos. 18<br>Name: Plain washer<br>Quantity: 2<br>Dim.: Ø 13 mm<br>    |
| Pos. 2<br>Name: Tow ball<br>Quantity: 1<br>                        | Pos. 7<br>Name: Angle bracket<br>Quantity: 2<br>                                    | Pos. 13<br>Name: Bolt 8,8 B<br>Quantity: 6<br>Dim.: M10x40mm<br> | Pos. 19<br>Name: Plain washer<br>Quantity: 8<br>Dim.: Ø 10,5 mm<br>  |
| Pos. 3<br>Name: Socket plate<br>Quantity: 1<br>                    | Pos. 8<br>Name: Jib<br>Quantity: 2<br>  | Pos. 14<br>Name: Bolt 8,8 B<br>Quantity: 4<br>Dim.: M8x35mm<br>  | Pos. 20<br>Name: Plain washer<br>Quantity: 4<br>Dim.: Ø 8,5 mm<br>   |
| Pos. 4<br>Name: Bracket<br>Quantity: 2<br>                         | Pos. 9<br>Name: Washer<br>Quantity: 2<br>   | Pos. 15<br>Name: Nut 8 B<br>Quantity: 2<br>Dim.: M12<br>         | Pos. 21<br>Name: Spring washer<br>Quantity: 2<br>Dim.: Ø 12,2 mm<br> |
| Pos. 5<br>Name: Washer<br>Quantity: 2<br>Dim.: Ø30xØ10,5x2,5mm<br> | Pos. 10<br>Name: Distance sleeve<br>Quantity: 2<br>Dim.: Ø17.2x2.35mm<br>L=39mm<br> | Pos. 16<br>Name: Nut 8 B<br>Quantity: 8<br>Dim.: M10<br>         | Pos. 22<br>Name: Spring washer<br>Quantity: 8<br>Dim.: Ø 10,2 mm<br> |
| Pos. 11<br>Name: Bolt 8,8 B<br>Quantity: 2<br>Dim.: M12x75mm<br>   | Pos. 17<br>Name: Nut 8 B<br>Quantity: 4<br>Dim.: M8<br>                             | Pos. 17<br>Name: Nut 8 B<br>Quantity: 4<br>Dim.: M8<br>          | Pos. 23<br>Name: Spring washer<br>Quantity: 4<br>Dim.: Ø 8,2 mm<br>  |
|   | Pos. 24<br>Name: Ball cover<br>Quantity: 1<br>                                     |   |  |

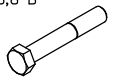
**Towing hitch (without electrical set)**

Class: **A50-X** Cat. no. **K02**

Designed for:

Manufacturer: **VOLKSWAGEN**

Model: **POLO**

Type: **FOX, 3 doors, ESTATE**

produced since 08.1990 till 09.1994

Technical data:

**D-value: 5,54 kN**

maximum trailer weight: **1000 kg**

maximum vertical cup load: **50 kg**

**Approval number according to Directive 94/20/EC: e20\*94/20\*1342\*00**

**Foreword**

This towbar is designed according to rules of safety traffic regulations. The towing hitch is a safety component and can be install only by qualified personnel. Any alteration or conversion of the towing hitch is prohibited and would lead to cancellation of design certification. Remove insulating compound and underseal from vehicle (if present) in the area of the matting surfaces of the towing hitch.

The vehicle manufacturer's specifications regarding trailer load and max. vertical cup load are decisive for driving whereat values for the towing hitch cannot be exceeded.

*D-value formula:*

$$\frac{\text{Max trailer weight [kg]} \times \text{Max vehicle weight [kg]}}{\text{Max trailer weight [kg]} + \text{Max vehicle weight [kg]}} \times \frac{9,81}{1000} = D \text{ [kN]}$$

## FITTING INSTRUCTION

Fig. 1

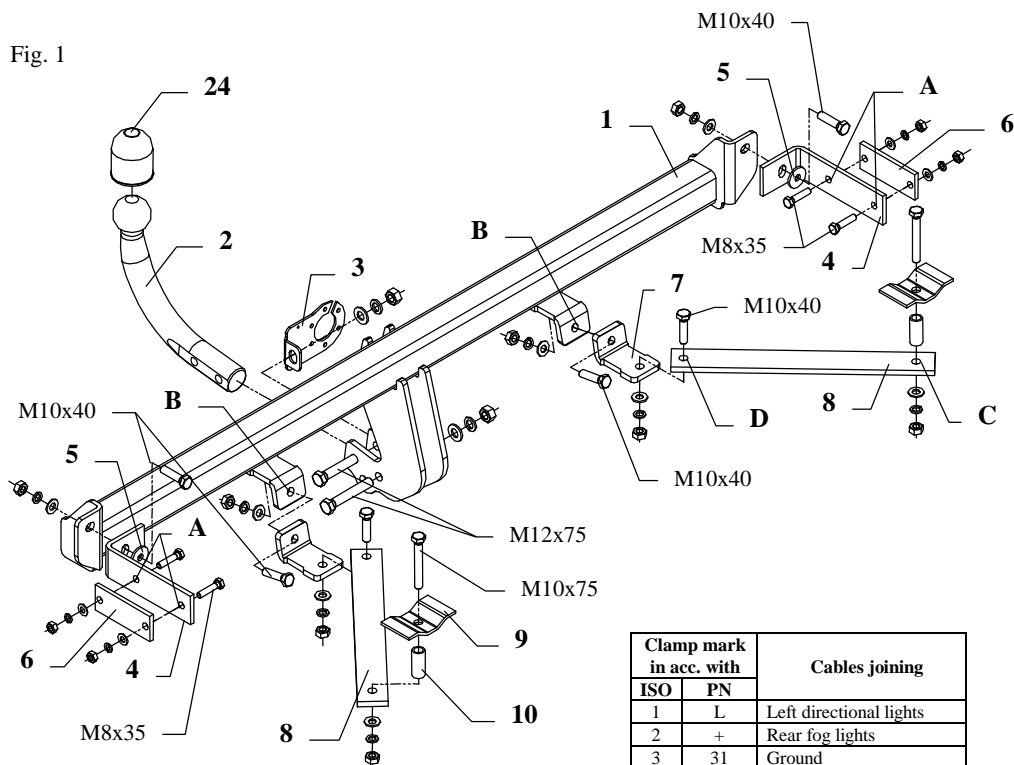

| Clamp mark in acc. with |     | Cables joining            |
|-------------------------|-----|---------------------------|
| ISO                     | PN  |                           |
| 1                       | L   | Left directional lights   |
| 2                       | +   | Rear fog lights           |
| 3                       | 31  | Ground                    |
| 4                       | R   | Right directional lights  |
| 5                       | 58R | Right side parking lights |
| 6                       | 54  | Stoptlights               |
| 7                       | 58L | Left side parking lights  |

This towbar is designed to assembly in following cars: **VOLKSWAGEN POLO FOX, 3 doors, ESTATE**, produced since 08.1990 till 09.1994, catalogue no. **K02** and is prepared to tow trailers max total weight **1000 kg** and max vertical load **50 kg**.

### From manufacturer

Thank you for buying our product. Their reliability has been confirmed in many tests. Reliability of towbar depends also on correct assembly and right operation. For this reasons we kindly ask to read carefully this instruction and apply to hints.

*The towbar should be install in points described by a car producer.*

## The instruction of the assembly

1. Disassemble the bumper.
2. On the back piece are clearly embossed points which one ought to drill with the bit  $\phi 11\text{mm}$ .
3. Apply the main bar of the towbar (pos. 1) on bored holes and fix using bolts M10x40mm (pos. 13) through brackets (pos. 4), which one ought to place inside the trunk (on the right and left side). Use washers  $\phi 30 \times \phi 10,5 \times 2,5\text{mm}$  (pos. 5).
4. Through holes (pos. A) of brackets (pos. 4) drill holes  $\phi 9\text{mm}$  and then fix using bolts M8x35mm (pos. 14) through plate (pos. 6).
5. Through holes (pos. B) of the towbar drill (in the back piece) holes  $\phi 11\text{mm}$  and fix with bolts M10x40mm (pos. 13) through angle brackets (pos. 7), which one ought to place from the internal side of the back piece, as showed on the fig. 1.
6. In the chassis member are holes  $\phi 11\text{mm}$  (from the bottom of the car by piece from the right and left side), which one ought to drill throughly with the bit  $\phi 11\text{mm}$ . Then, in part trunk, drill on the diameter  $\phi 17\text{mm}$ . Into so prepared holes put distance sleeves L=39mm (pos. 10), apply fish-plates (pos. 9) and put bolts M10x75mm (pos. 12), as showed on the fig. 1.
7. So prepared elements of the towbar fix with jibs (pos. 8) in marked points (pos. C and D).
8. Install the bumper after cut out of its fragment 50x150mm, as showed on the fig. 2.

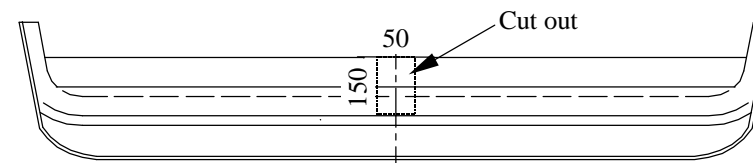

Fig. 2

9. Fix tow-ball (pos. 2) and socket plate (pos. 3) by bolts M12x75mm (pos. 11) from accessories.
10. Tighten all bolts according to the torque shown in the table.
11. Connect electric wires of 7-poles socket according to the instruction of the car. (Recommend to make at authorized service station).
12. Complete paint layer damaged during installation.

|   |                      |
|---|----------------------|
| Torque settings for nuts and bolts (8,8): |                      |
| <b>M 8</b> - 25 Nm                        | <b>M 10</b> - 55 Nm  |
| <b>M 12</b> - 85 Nm                       | <b>M 14</b> - 135 Nm |

### NOTE

After install the towbar you should get adequate note in registration book (at authorised service station).The car should be equipped with:

- Indicators
- Tow mirrors

After 1000km of exploitation check all bolts and nuts. The ball of towbar must be always kept clear and conserve with a grease.



[ahkupplungen.de](http://ahkupplungen.de)